

USER AND MAINTENANCE MANUAL

MERCEDES-BENZ SPRINTER BE-Combination

3500PLUS

B23DL & B24DL



No part of this document may be reproduced and/or published without written permission from BE-Combi Systems.
BE-Combi Systems reserves the right to make changes without prior notice.

© Copyright BE-Combi Systems, Vuren, The Netherlands

09-2023 V1.1 EN



TABLE OF CONTENTS

TABLE OF CONTENTS	3
1 INTRODUCTION	4
2 USER MANUAL	5
2.1 GENERAL.....	5
2.2 MAXIMUM PERMISSIBLE PAYLOAD.....	6
2.3 TACHOGRAPH.....	7
2.4 COMMISSIONING.....	7
2.5 CONNECTING AND DISCONNECTING VEHICLE AND TRAILER.....	8
2.6 SYSTEM DESCRIPTION AND INSTRUCTIONS.....	11
2.6.1 Intelligent Braking System (IBS) operation and display.....	11
2.6.2 Fifth wheel.....	13
2.6.3 Park and brake valve.....	13
2.6.4 Semi-trailer parking brake.....	14
2.6.5 Plug connection terminal.....	15
2.6.6 Tail lift controls (optional).....	16
2.6.7 Trailer height controls (optional).....	16
3 MAINTENANCE MANUAL	17
3.1 AIR SYSTEM.....	17
3.2 COUPLING CONNECTION.....	19
3.3 SEMI-TRAILER AXLE.....	20
3.4 BRAKE SYSTEM AND BLEEDING.....	21
3.5 AIR SUSPENSION.....	23
3.6 FUSES.....	24
4 MALFUNCTIONS	25
4.1 CAUSES AND SOLUTIONS.....	25
4.2 IBS ERROR CODE READOUT.....	28
APPENDIX A	30



1 INTRODUCTION

This user and maintenance manual describes the operations required to couple a 3500PLUS trailer to its corresponding truck. Furthermore, this manual provides instructions to perform periodic maintenance on an entire 3500PLUS System, which is equipped with IBS (Intelligent Braking System). This manual is applicable for the following models:

- B23DL, wheelbase 3665mm
- B24DL, wheelbase 4325mm

Follow the instructions at all times, always adhere to general safety and environmental regulations. Please contact BE-Combi Systems if you have any questions and/or comments.



2 USER MANUAL

2.1 General

Features of a 3500PLUS System:

- The towing vehicle is equipped with a subframe, on which a fifth wheel is mounted.
- The 3500PLUS trailer is coupled to this fifth wheel while the trailer rests entirely on the subframe.
- Through an air compressor on the vehicle, the trailer is supplied with air for brakes and air suspension.
- The vehicle and trailer are coupled and secured rigidly, so it is not a hinged structure like a regular trailer / truck combination.
- Driver must have a BE driver's licence, either from before 19-01-2013 or after 19-01-2013.
- The speed limit is **80 km/h** (locally applicable laws and regulations apply).
- The maximum permissible vehicle / trailer combination is always **7000 kg**.

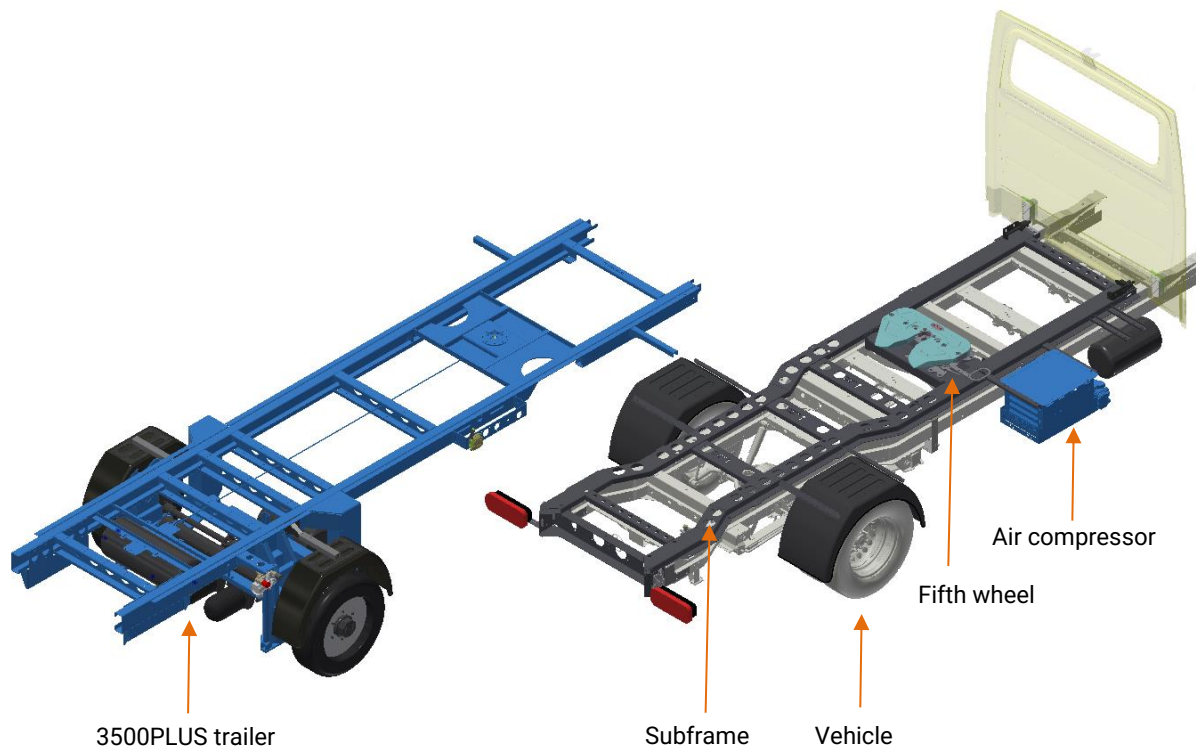

2.2 Maximum permissible payload

The maximum payload for a 3500PLUS System is different for each vehicle/trailer combination. The example below must be adhered in order to determine the maximum payload.

- Max. gross vehicle / trailer combination weight is always **7000 kg**.
- The permissible fifth wheel load is the difference between gross and kerb vehicle weight, which pushes downwards on the fifth wheel on the vehicle.
- This fifth wheel load is included in the gross trailer weight.
- The kerb weight varies by type of vehicle and trailer. This affects the permissible fifth wheel load and so maximum payload.

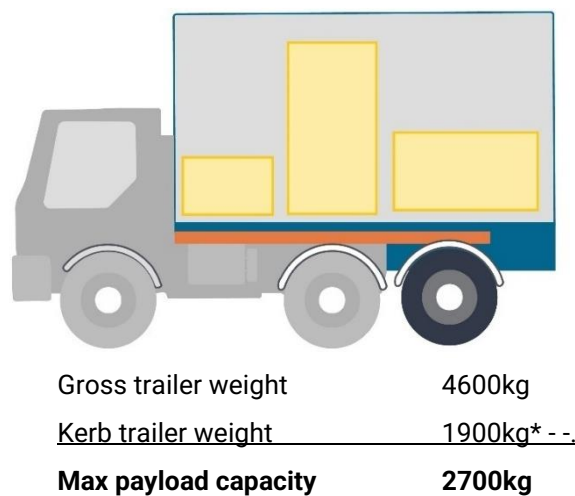
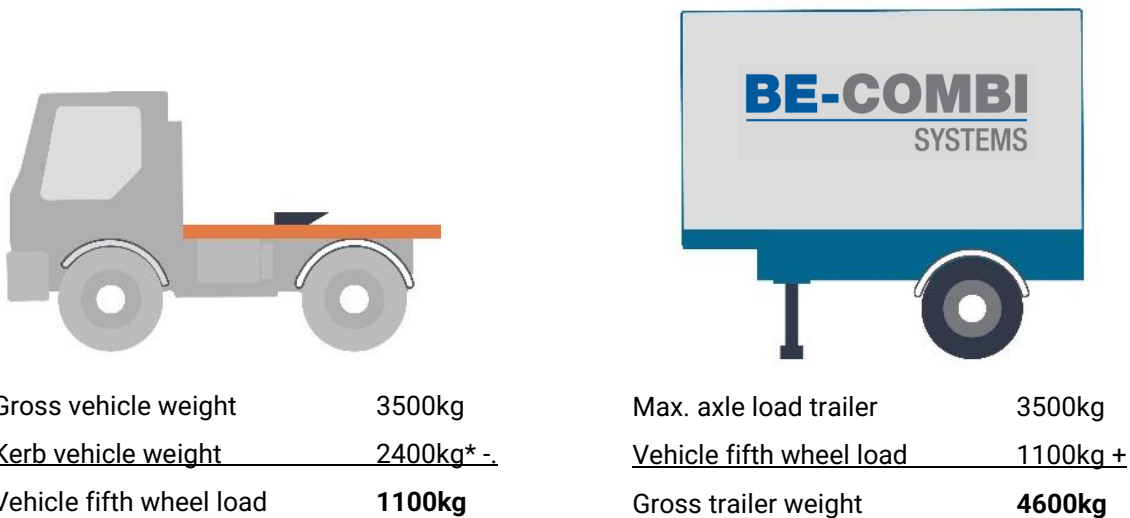

* Use the correct kerb vehicle and trailer weights as specified in the corresponding registration certificate.

2.3 Tachograph

The vehicle combined with a 3500PLUS System is tachograph-compliant. Refer to the tachograph instruction book for its correct use in conjunction with local applicable laws and regulations. Make sure the following actions are carried out:

- On first use, insert the company card into the tachograph to link the company to the vehicle. When doing so, enter the correct registration number of the towed vehicle.
- Before starting each trip, insert the driver card into the tachograph.
- The tachograph and driver's card are legally required to be read out regularly to check driving and rest periods. In doing so, always follow the local applicable laws and regulations.

2.4 Commissioning

After the new vehicle has been delivered with the 3500PLUS trailer, the entire combination requires a short running in period. If there are any problems, contact your dealer.

- The vehicle should run in according to the specifications of the manufacturer in the corresponding owner's manual.
- **First 50 km** - Check trailer wheel nuts for correct tightening torque of **320Nm** and even **tyre wear**.
- **First 100 km** - It is **important to brake** the 3500PLUS trailer **intensively** to allow the brake drum and brake shoe to wear into each other. Keep general road safety in mind.



2.5 Connecting and disconnecting vehicle and trailer

The correct connecting and disconnecting procedure of vehicle and trailer are shown in detail in an animation, accessible via the QR code or via the URL link below. The trailer is fit for purpose for the type of vehicle and not exchangeable with any other type of vehicles.



www.be-combi.com/technical-documentation/videos

CAUTION! Images and animations may vary by type of vehicle and trailer.



- Vehicle and trailer are coupled here
- After docking, always check the following procedures



- After coupling the vehicle and trailer, check the removal of the left and right trailer support

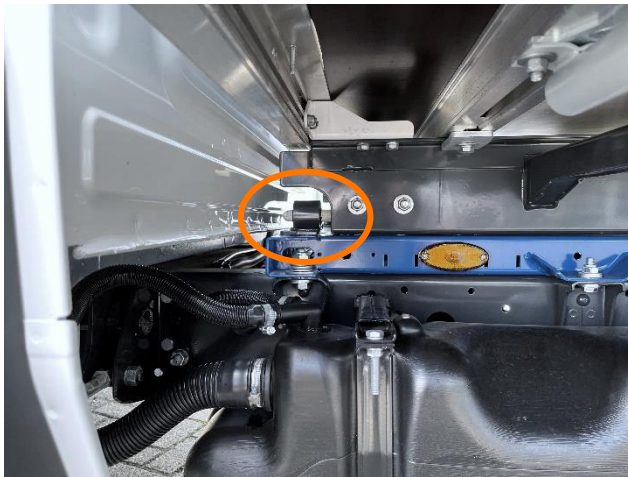

- After coupling, check whether the left and right guide pins behind the vehicle cab are correctly positioned in their guide rails



- Check that the fifth wheel lever on the passenger side is fully retracted and secured by the locking lever



- Check the left and right rear of the trailer for correct positioning of hook clamps



- Visually inspect the left and right trailer wheels and wheel nuts for any damage or incorrect mounting
- Visually check the left and right air bellows and shock absorbers for cracks or leaks



- Check if the trailer parking brake is released, operated by the spindle on the driver's side

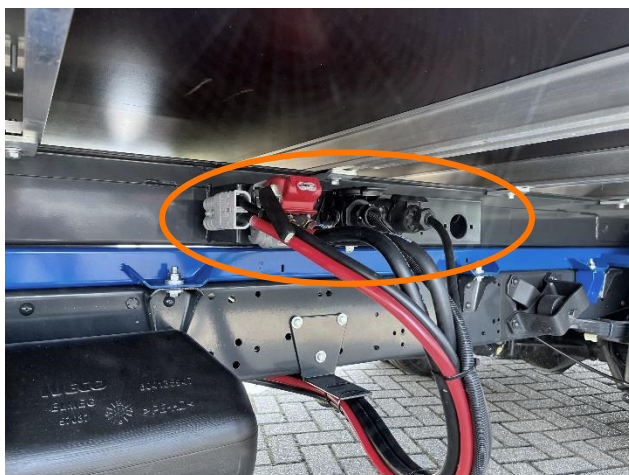

- Check if all plugs are connected to the driver or passenger side terminal board (depending on model)
 - Duomatic
 - 13-pin plug
 - EBS plug
 - Tailgate Harrison plug (optional)
 - Height control plug (optional)
 - Rear view camera (optional)



- Check the cabin dashboard control panel whether IBS is fault free
- 3x LED indicator when ignition switched on
- Short trailer brake operation is audible
- 3x LED indicator should go out
- See also section 2.6.1

2.6 System description and instructions

This section describes the various systems with their associated instructions, which are present on the 3500PLUS System.

2.6.1 Intelligent Braking System (IBS) operation and display

The IBS ensures that the ESP, ABS, AEBS and ASR signals from the vehicle are transmitted to the trailer's braking system for optimum safety. The system complies with the GSR2 regulations, which are in force as of 07-07-2024.



- The IBS control panel is center mounted on the dashboard as shown.
- The IBS continuously performs a self-diagnosis upon startup and while driving, any malfunctions are displayed immediately.



- When ignition is turned on, 3x lights light up briefly at the same time.
- The right ABS light is the diagnostic check for the trailer brakes.
- If there is no fault, this light turns off immediately or after reaching a speed of up to 10 km/h.



- The left red and centre orange lights light up briefly, during this check the air brakes are audibly operated briefly 1x.
- After this check, the lights go out.



- When operating correctly, all lights are off.

If a light stays on, there is a malfunction in the IBS, see also chapter 0:

- **Red light** - IBS malfunction where electronic brake control is converted to mechanical emergency brake control. **CAUTION!** Semi-trailer remains braked at all times, however, with higher brake pedal resistance. Consult your dealer immediately.
- **Orange light centre** - minor malfunction where IBS remains active. Consult dealer at first opportunity.
- **Orange light right** - trailer brake failure. Semi-trailer brakes at maximum pressure using the back-up system. Consult dealer at first opportunity.

2.6.2 Fifth wheel



- The fifth wheel provides the mechanical coupling between the vehicle and trailer.
- The fifth wheel is positioned on the vehicle's subframe.
- The fifth wheel is equipped with two levers.
 - Locking lever - push it down to operate the coupling lever.
 - Coupling lever - pull out the coupling lever in order to couple the trailer, see also section 2.5.

2.6.3 Park and brake valve

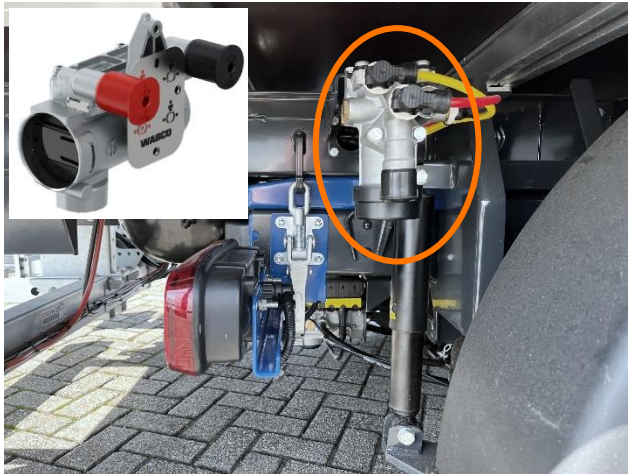

- The valve must be used to park the trailer braked or unbraked when uncoupled from the vehicle.
- The valve is positioned at the rear of the trailer on the passenger's side
 - Black button out Trailer brake fixed (happens automatically when uncoupling)
 - Black button in Semi-trailer brake released
- **CAUTION!** Never operate the black button if the trailer is uncoupled on a slope, always use the parking brake for this, see section 2.6.4.

Older types of trailers are equipped with a different valve with an air-operated parking brake, (additional red button).

- Black button out Trailer brake fixed (happens automatically when uncoupling)
- Black button in Semi-trailer brake released
- Red button out Parking brake fixed
- Red button in Parking brake released (must always be done manually with a coupled and uncoupled trailer)

2.6.4 Semi-trailer parking brake



- Under normal operating conditions, the trailer parking brake must not be used. The vehicle's handbrake is powerful enough for a 7000 kg combination on a steep slope.
- Only use the parking brake with the trailer uncoupled on a steep slope
- The parking brake is positioned at the rear end of the trailer on the driver's side
- Turn the crank counterclockwise to activate the parking brake
- Turn the crank clockwise to deactivate the parking brake

2.6.5 Plug connection terminal

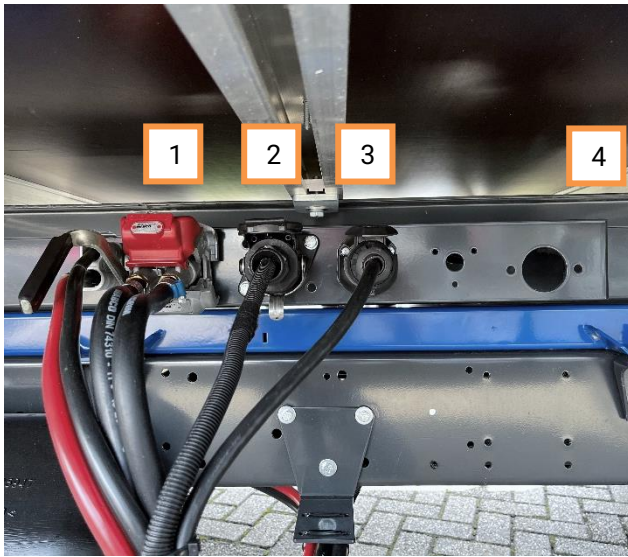

- All plugs between the vehicle and trailer are connected on the connection terminal on the front of the trailer.

- Fixed connections:

1. Duomatic – provides supply pressure and power steering air pressure. Open the red cover and push the handle down. Then hook the connection into the connection terminal block. Check connection properly.

2. EBS plug – controls the anti-lock system. Open valve and push plug in. Lock by metal bracket.

3. 13-pin plug – controls the lights
Open the valve and turn the bayonet socket clockwise until plug is pulled fully into the socket.

4. Diagnostic EBS plug – is not connected. Dealer uses this for failure analysis of the EBS unit

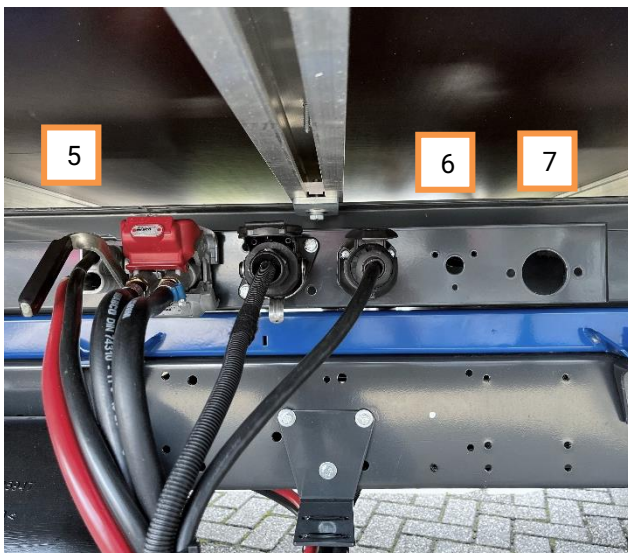

- Optional connections

5. Harrison plug – high current for e.g. tail lift. Push plug straight into holder.

6. 3-pin plug – height control is controlled from the cab. Open cover and push plug into plug box, form-fitting (not shown in image).

7. Camera plug – power and signal for rear view camera. Open cover and push plug into power socket, form-fitting (not shown in image).

2.6.6 Tail lift controls (optional)



- The tail lift controls are located on the rear end and passenger side of the trailer
- Refer to the tail lift supplier's manual for the proper operation

2.6.7 Trailer height controls (optional)

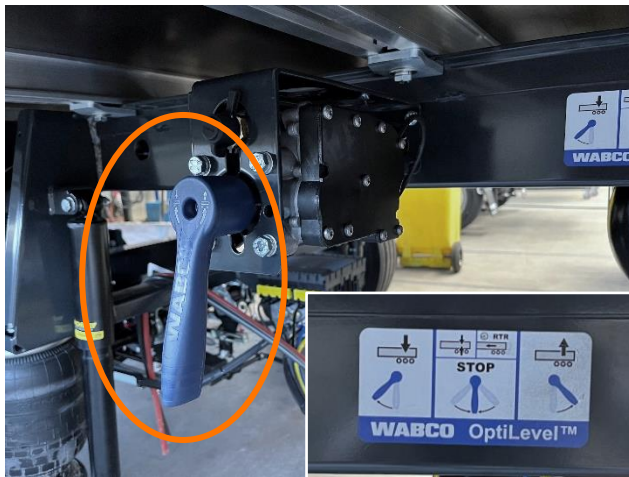

- With the height control, it is possible to vary the loading floor height
- The height control can also act as a traction control on slippery surfaces. Reducing the trailer axle load adds more pressure on the vehicle's driving axle
- Valve and instructions are positioned at the rear end of the trailer on the driver's side



- The vehicle is also equipped with a joystick for operating height control from the cab
- Position: right side of drivers seat
 - Joystick up - trailer axle up
 - Joystick down - trailer axle down
- **CAUTION!** Height control only works while stationary and up to 10 km/h
- Above 10 km/h, the axle automatically returns to driving position

3 MAINTENANCE MANUAL

The maintenance required on the 3500PLUS System is shown below.

- This manual only describes the 3500PLUS System. The vehicle should be serviced as specified by the manufacturer.
- Regular maintenance should be carried out at least every **six months**.
- In accordance with local laws and regulations, the vehicle and trailer should be legally inspected at regular intervals.
- Maintenance must be carried out by qualified personnel in accordance with the general applicable safety and environmental regulations.

Period	Air system	Coupling connection	Semi-trailer axle	Brake system	Air suspension
First use			X		
Every 6 months	X	X	X	X	X
Every 12 months	X				

3.1 Air System

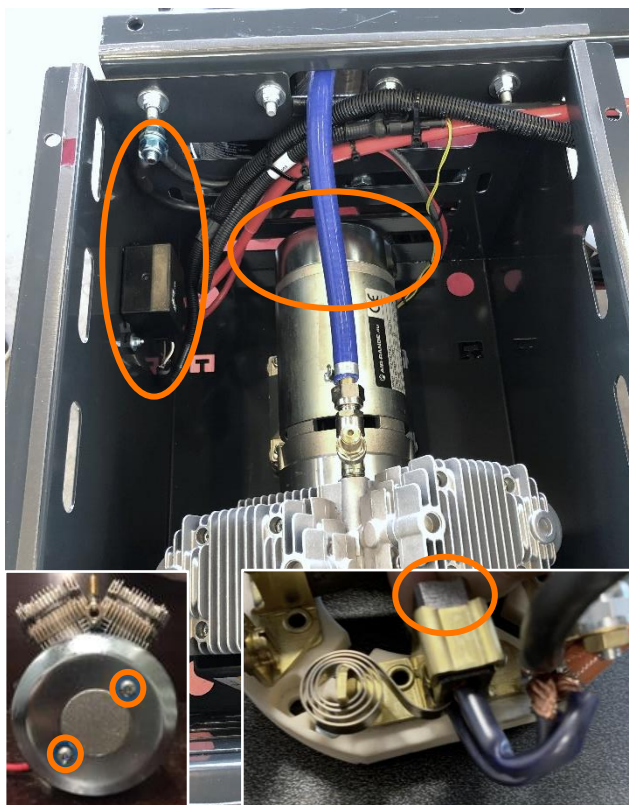

- Remove the cover of the compressor box, by means of 4 bolts
- Remove the cover of the compressor motor, by means of 2 screws
- Check the carbon brushes on the compressor motor. Replace the carbon brushes if the carbon brush length is the same as the holder
- Check the wiring to the relay and the earth point
- Check all air connections for leakages



- Replace **annually** the air dryer filter on the outside of the compressor bin
- Disconnect the Duomatic to prevent deflation of the trailer air system
- **CAUTION!** Remove full air pressure from vehicle system, via air tank drain valve plug
- Remove the air filter
- Apply grease to the rubber O-ring
- Install new air filter hand-tight (15 Nm)



- Drain water at the 3x air tanks
- Pull ring to the left or right until no more water comes out
- Check air tanks and brackets for corrosion and replace if necessary
- 2x air tank trailer
- 1x air tank vehicle

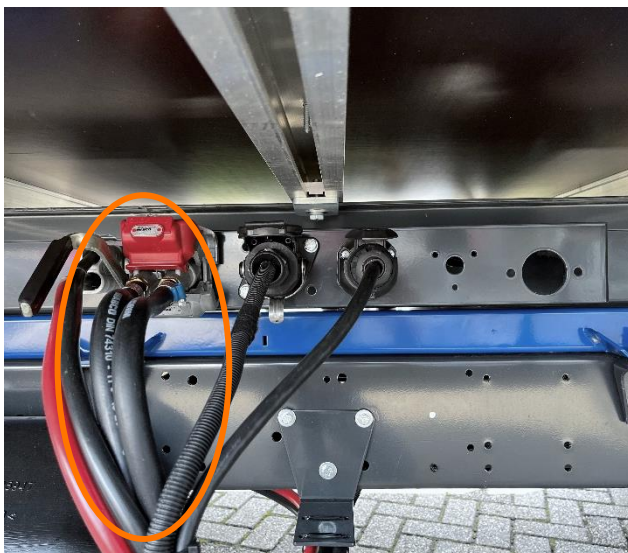

- Check all rubber air hoses for cracks and leaks
- Replace if necessary

3.2 Coupling connection

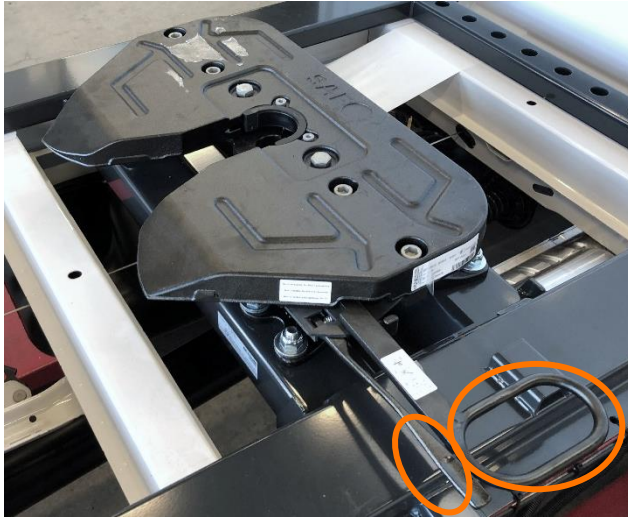

- Check the bolt connection of the fifth wheel on the subframe. Tightening torque **260 Nm**
- Apply graphite grease on the entire top side of the fifth wheel



- Check the kingpin bolt connection. Tightening torque **130 Nm**

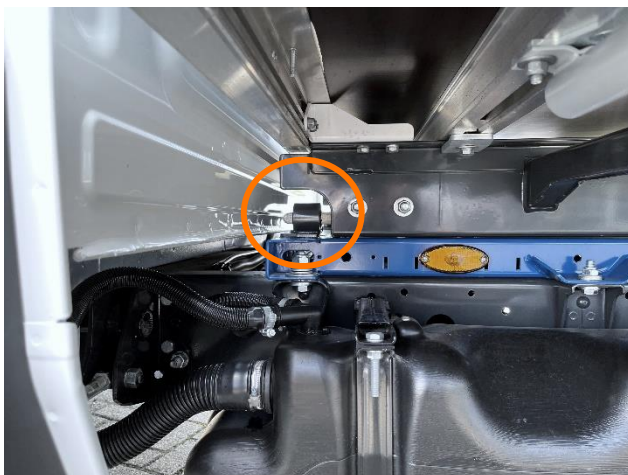

- Lubricate the pin on the front left and right sides of the fifth wheel with ceramic grease

3.3 Semi-trailer axle



- Lubricate the axle with high pressure grease (EP)
- Pump grease into grease nipple 6x until grease is flowing out the axle
- Anchor plate, left and right sides (2x)
- Slack adjusters, left and right sides (4x)



- Position of grease nipple on anchor plate, left and right sides

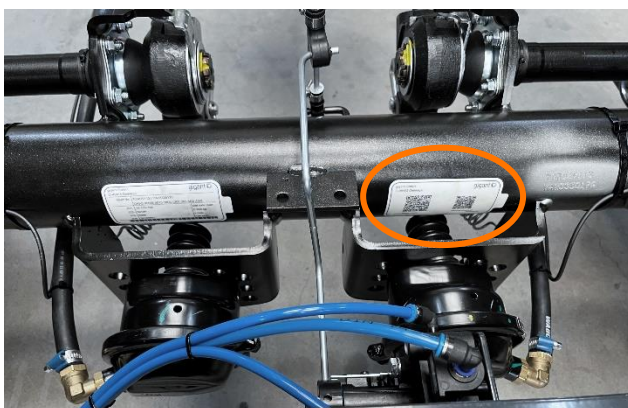

- Scan the QR code on the Gigant axle for the correct maintenance manual



- Check and set tyre pressure to **7 bar**
- Check wheel nuts, tightening torque **320 Nm**
- Check tyres for even wear
- Align trailer if wear is uneven
- Check wheel bearing for play or noise, replace wheel bearing or hub if necessary

3.4 Brake system and bleeding

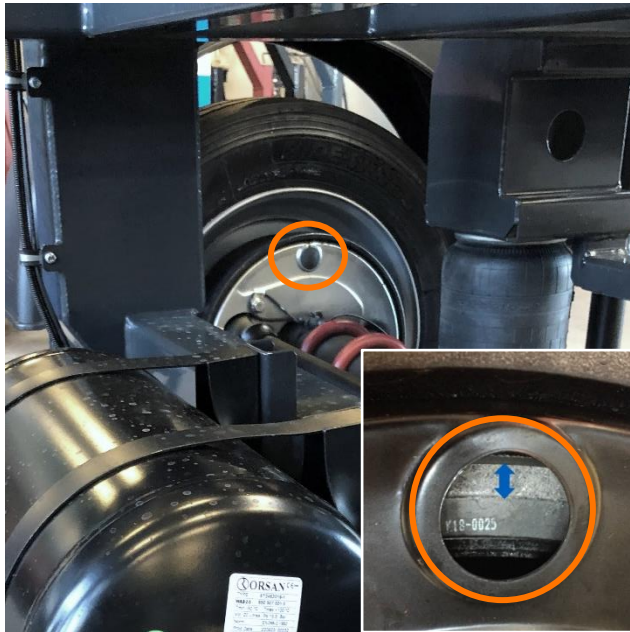

- Check trailer brake lining for damage, replace as necessary.
- Remove the cap on the inside of the axle as shown. Check the thickness of the brake lining. Replace brake lining when the area of light grey is less than 2 mm.



- Check if the distance between the automatic slack adjusters is parallel.
- Measure both slack adjusters to a fixed point; these measurements should be the same. Adjust the position as follows if they are not equal:
- Jack up the axle so that both wheels rotate freely.
- Tighten the adjustment bolt (indicated) until the brakes are tight. Then turn back $\frac{3}{4}$ turn so that the wheels spin freely.
- Operate brake pedal briefly 3x.
- Repeat this procedure on other side.



- If work has been done on the vehicle's hydraulic brake system, the IBS brake system should be bled in addition to the regular bleed points on the brake calipers.

- Bleed the vehicle's brake system in the following order:

1. Inverter valve (2x nipple) – indicated position in engine bay (see image)

2. Sensor bleed nipples (4x bleed nipple) – Bleed 4x sensor bleed nipple. Hold hose in upright position in case finding difficulties to bleed.

3. Vehicle - regular way as specified by the manufacturer

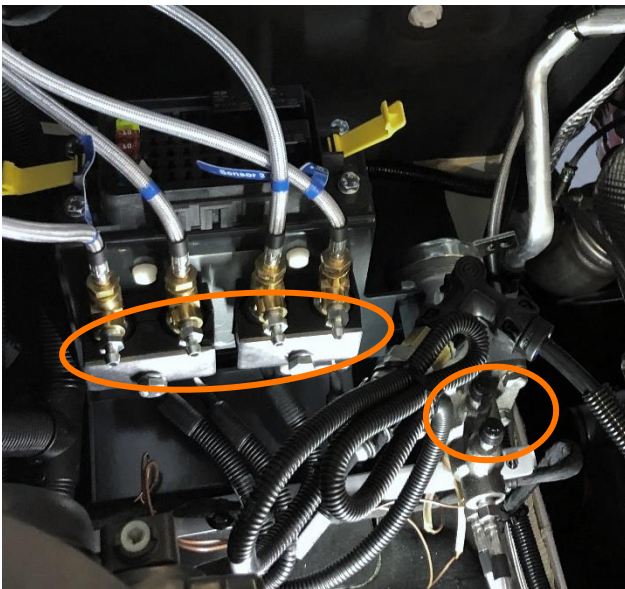

3.5 Air suspension



- Check left and right air bellows for dryness and cracks, specifically around the lower and upper curves
- Replace as necessary
- Check shock absorbers for oil leakages
- Replace if necessary

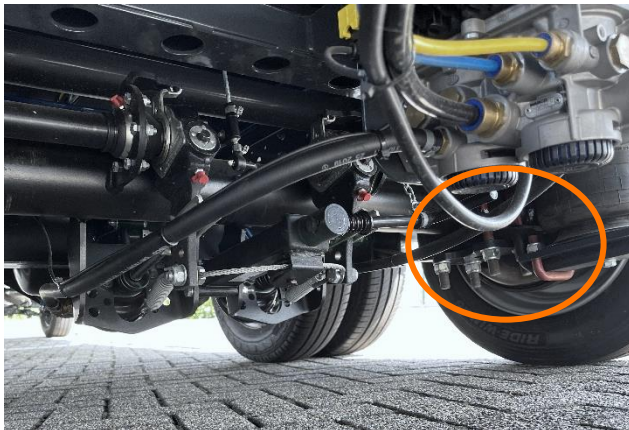

- Check the nuts on the U-bolts. Tightening torque **550 Nm**

3.6 Fuses



- The main fuses are located in the vehicle's battery box and below the driver's seat as shown in the picture

- Compressor fuse **125 amp**
- IBS computer fuse, F1 **60 amp**



- The IBS fuses are located in the fuse box of the IBS computer in the vehicle as shown

4 MALFUNCTIONS

4.1 Causes and solutions

Possible malfunctions in the 3500PLUS System can be remedied using the instructions below.

Malfunction	Causes	Solutions
Brakes		
Trailer brakes squeak	Insufficient lubrication of brake axles	Lubricate anchor plate and slack adjusters as shown in section 3.3
	Brakes not properly worn in	Brake trailer several times very intensively to allow brake drum and brake shoe to wear into each other. Keep in mind overall road safety, see also section 2.4
	Glazed brake lining	Check brake lining for any glazing and replace if not remedied with intense braking.
Pneumatic malfunction		
Air pressure drops by more than 2.5 bar after 12 hrs	Air leakage in pneumatic system	Find the air leak and replace the affected parts.
Air pressure lower than 5.5 bar IBS display warning lamp 'red' CAUTION! Brakes of trailer may lock	Air leakage in pneumatic system	To prevent damage, put the brakes in the transport position. - <i>Type spring brake booster large with 2x input hose:</i> Disconnect the Duomatic from the trailer. Drain the rear large air tank under the trailer, using the dewatering valve. Unscrew the bolts on the underside of the brake booster. The screw thread should protrude at least 15 cm before the brakes are in the transport position.  - <i>Type spring brake booster small with 1x inlet hose:</i> Disconnect the Duomatic from the trailer. Drain the

		<p>rear large air tank under the trailer, using the dewatering valve. The brakes are off.</p> <p>Fix the air leak and remove the brake boosters from the transport position.</p>
No air pressure at all	Air leakage in pneumatic system	The brakes of the trailer are blocked. Put the brake boosters in the transport position as described above.
Air pressure not above 6.5 bar	Pressure regulator defective	Check the pressure regulator and replace as necessary.
Compressor does not turn on	No electrical power supply	Check compressor wiring and/or fuse. Replace as necessary, see section 0.
	Carbon brushes worn	Check the compressor motor carbon brushes if this is difficult or slow to turn on, or if the fuse blows immediately. Replace as necessary.
	Compressor overheated	Allow to cool with ambient air. This process can be accelerated by removing the compressor box cover and reinstalling it after cooling.
Compressor does not turn off	Air leakage outside the compressor	Find the air leak and replace the affected parts.
	Air leakage inside the compressor	System is not building up pressure. Check the piston rings for wear. Replace as necessary.
IBS malfunction (indicated on dashboard display)		
IBS light is red (left)	IBS computer malfunction	Read out trailer fault memory using IBS tool, see section 4.2
IBS light is orange (centre)	IBS computer malfunction	Read out trailer fault memory using IBS tool, see section 4.2
EBS lamp is orange (right)	Malfunction in ABS braking system on trailer	Fault must be read out using WABCO diagnostic equipment, available at the relevant truck dealer or trailer service point



The trailer brake diagrams can be accessed via the QR or the link underneath.



www.be-combi.com/technical-documentation/brakeplans

4.2 IBS error code readout

In the event of an IBS system malfunction, the error codes can be read out through an **IBS tool**, available at BE-Combi Systems.



- Remove the indicated panel
- Behind this is a 6-pin white plug marked 'X001'
- Connect the IBS tool to the plug
- The IBS tool starts up immediately once connected, the first program takes 20 sec
- Every consecutive 1-2 seconds, the IBS tool displays information and shows the system pressures in Bar (starts at 4 sec)
- The subsequent step is represented by HS... or PS... as shown in the table
- The table below gives an overview of the time and description.

Time [sec]	Description	Display view
0-1	Software version number	S020
2-3	Configuration parameter number	P010
4-5	Supply pressure in port 11	8.88b
6		HS1
7-8	Hydraulic pressure on sensor #1	44.4b
9		HS2
10-11	Hydraulic pressure on sensor #2	44.4b
12		HS3
13-14	Hydraulic pressure on sensor #3	44.4b
15		HS3
16-17	Hydraulic pressure on sensor #4	44.4b
18		PS5
19-20	Air pressure backup sensor port 42	4.44b

After this sequence, the Diagnostic Trouble Codes (DTC) stored in the memory will be displayed.

CAUTION! The IBS tool will only display active and inactive codes stored in the last 24 working hours.

If no DTCs are known, the sequence stops. If DTCs are known, they will be displayed as follows.

Time [sec]	Description	Display view
22	Diagnostic Trouble Code #1	F001
23	Diagnostic Trouble Code #2	F050.
24	Diagnostic Trouble Code #3	F048
25	Diagnostic Trouble Code #4	F034.
26	Diagnostic Trouble Code #5	F022
27		---
28	Diagnostic Trouble Code #1	F001
29	Diagnostic Trouble Code #2	F050.
	Etc*	

* If DTCs are present, the IBS tool will keep repeating them.

--- Indicates restart of the DTC cycle.

CAUTION! DTCs with a dot indicate an active fault.

If **no** dot appears behind the DTC, it indicates an inactive fault which was active for the last 24 working hours.

Example of an active DTC

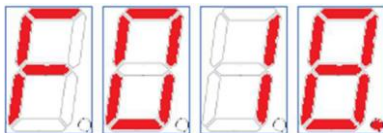

Example of an inactive DTC

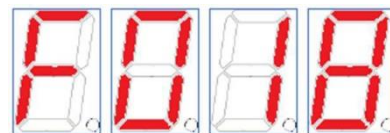

The given error codes with possible solution can be looked up in appendix A, or using the link or QR code shown below.



www.be-combi.com/technical-documentation/ibs

APPENDIX A

DTC	EPR0M	Description #1	Description #2	Lamp	Remarks	Pin on IBS ECU:	Sensor / Actuator:	Possible Solution:
F000	DWORD00.80	not used						
F001	DWORD00.81	Hydraulic Sensor #1	value above normal range	Red/Amber	1 sensor failed? -> Amber Lamp >1 sensors failed? -> Red Lamp	J4	B001	- Check Wiring to Hydraulic Sensor - Check/Replace Fuse to power supply of Sensors - Replace Hydraulic Sensor
F002	DWORD00.82	Hydraulic Sensor #1	value below normal range	Red/Amber	1 sensor failed? -> Amber Lamp >1 sensors failed? -> Red Lamp			
F003	DWORD00.83	Hydraulic Sensor #1	driver error	Red/Amber	1 sensor failed? -> Amber Lamp >1 sensors failed? -> Red Lamp			
F004	DWORD00.84	Hydraulic Sensor #2	value above normal range	Red/Amber	1 sensor failed? -> Amber Lamp >1 sensors failed? -> Red Lamp	H4	B002	- Check Wiring to Hydraulic Sensor - Check/Replace Fuse to power supply of Sensors - Replace Hydraulic Sensor
F005	DWORD00.85	Hydraulic Sensor #2	value below normal range	Red/Amber	1 sensor failed? -> Amber Lamp >1 sensors failed? -> Red Lamp			
F006	DWORD00.86	Hydraulic Sensor #2	driver error	Red/Amber	1 sensor failed? -> Amber Lamp >1 sensors failed? -> Red Lamp			
F007	DWORD00.87	Hydraulic Sensor #3	value above normal range	Red/Amber	1 sensor failed? -> Amber Lamp >1 sensors failed? -> Red Lamp	A4	B003	- Check Wiring to Hydraulic Sensor - Check/Replace Fuse to power supply of Sensors - Replace Hydraulic Sensor
F008	DWORD00.88	Hydraulic Sensor #3	value below normal range	Red/Amber	1 sensor failed? -> Amber Lamp >1 sensors failed? -> Red Lamp			
F009	DWORD00.89	Hydraulic Sensor #3	driver error	Red/Amber	1 sensor failed? -> Amber Lamp >1 sensors failed? -> Red Lamp			
F010	DWORD00.810	Hydraulic Sensor #4	value above normal range	Red/Amber	1 sensor failed? -> Amber Lamp >1 sensors failed? -> Red Lamp			
F011	DWORD00.811	Hydraulic Sensor #4	value below normal range	Red/Amber	1 sensor failed? -> Amber Lamp >1 sensors failed? -> Red Lamp	A3	B004	- Check Wiring to Hydraulic Sensor - Check/Replace Fuse to power supply of Sensors - Replace Hydraulic Sensor
F012	DWORD00.812	Hydraulic Sensor #4	driver error	Red/Amber	1 sensor failed? -> Amber Lamp >1 sensors failed? -> Red Lamp			
F013	DWORD00.813	Air Pressure Sensor Port 11	value above normal range	Red	1 sensor failed? -> Amber Lamp >1 sensors failed? -> Red Lamp			
F014	DWORD00.814	Air Pressure Sensor Port 11	value below normal range	Red	1 sensor failed? -> Amber Lamp >1 sensors failed? -> Red Lamp	C4	B006	- Check Wiring to Pressure Sensor - Check/Replace Fuse to power supply of Sensors - Replace Pressure Sensor
F015	DWORD00.815	Air Pressure Sensor Port 11	driver error	Red	1 sensor failed? -> Amber Lamp >1 sensors failed? -> Red Lamp			
F016	DWORD00.816	Air Pressure Sensor Port 22	value above normal range	Red	1 sensor failed? -> Amber Lamp >1 sensors failed? -> Red Lamp			
F017	DWORD00.817	Air Pressure Sensor Port 22	value below normal range	Red	1 sensor failed? -> Amber Lamp >1 sensors failed? -> Red Lamp	D4	A002	- Check Wiring to Pressure Sensor - Replace Pressure Sensor
F018	DWORD00.818	Air Pressure Sensor Port 22	driver error	Red	1 sensor failed? -> Amber Lamp >1 sensors failed? -> Red Lamp			
F019	DWORD00.819	Air Pressure Sensor Port 42	value above normal range	Red	1 sensor failed? -> Amber Lamp >1 sensors failed? -> Red Lamp			
F020	DWORD00.820	Air Pressure Sensor Port 42	value below normal range	Red	1 sensor failed? -> Amber Lamp >1 sensors failed? -> Red Lamp	E4	B005	- Check Wiring to Pressure Sensor - Check/Replace Fuse to power supply of Sensors - Replace Pressure Sensor
F021	DWORD00.821	Air Pressure Sensor Port 42	driver error	Red	1 sensor failed? -> Amber Lamp >1 sensors failed? -> Red Lamp			
F022	DWORD00.822	IBS CAN - CAN Signal "ASR Active"	timeout or signal error	Amber		J3 or K3	A003 / R001 / R002	- Check Wiring to CAN-Crocodile/Termination resistor - Check/Replace Fuse to power supply of CAN-Crocodile - Replace CAN-Crocodile
F023	DWORD00.823	IBS CAN - CAN Signal "Engine Speed"	timeout or signal error			J3 or K3	A003 / R001 / R002	- Check Wiring to CAN-Crocodile/Termination resistor - Check/Replace Fuse to power supply of CAN-Crocodile - Replace CAN-Crocodile
F024	DWORD00.824	Pressure Increase Failure	Plausibility check failed	Red		F1 or G1 or H1	A002	- Check Wiring to eTCV Valve
F025	DWORD00.825	Pressure Decrease Failure	Plausibility check failed	Red		F1 or G1 or H1	A002	- Check Wiring to eTCV Valve
F026	DWORD00.826	GND Failure	open circuit	Red		L3 and L4 and M3 and M4	GND Point connection	- Check GND Connection to IBS ECU
F027	DWORD00.827	eTCV Inlet Valve	short circuit (Protection Active)	Red				- Check Wiring to eTCV Valve
F028	DWORD00.828	eTCV Inlet Valve	current too low	Red		H1	A002	- Check GND Connection to eTCV Valve - Replace eTCV Valve
F029	DWORD00.829	eTCV Inlet Valve	open circuit	Red				- Check Wiring to eTCV Valve
F030	DWORD00.830	eTCV Discharge Valve	short circuit (Protection Active)	Red		G1	A002	- Check GND Connection to eTCV Valve - Replace eTCV Valve
F031	DWORD00.831	eTCV Discharge Valve	current too low	Red				- Check Wiring to eTCV Valve
F032	DWORD00.800	eTCV Discharge Valve	open circuit	Red				- Check Wiring to eTCV Valve
F033	DWORD00.801	eTCV Backup Valve	short circuit (Protection Active)	Red		F1	A002	- Check Wiring to eTCV Valve - Check GND Connection to eTCV Valve - Replace eTCV Valve
F034	DWORD00.802	eTCV Backup Valve	current too low	Red				- Check Wiring to eTCV Valve
F035	DWORD00.803	eTCV Backup Valve	open circuit	Red				- Check Wiring to eTCV Valve
F036	DWORD00.804	Configuration Checksum invalid		Red		Software	Wrong Configuration File!!	Check Software and Configuration File
F037	DWORD00.805	Configuration incompatible with Software Application		Red		Software	Wrong Configuration File!!	Check Software and Configuration File



